

SMALL FLANGE REMOTE SEAL TYPE DIFFERENTIAL PRESSURE TRANSMITTER

DATA SHEET

FKX...5/FDX...5

The FCX -AIII small flange remote seal type pressure differential transmitter accurately measures differential pressure and converts it into an output signal of 4~20mA DC.

The transmitter utilizes a unique micromachined capacitance silicon sensor with state-of-the-art microprocessor technology to provide exceptional performance and functionality. Its small volume, light weight, good environment adaptability, and applicable to all fields. If using the hand held communicator (sold separately), it can be set and display via remote operation, without affecting the DC 4~20mA output signal of transmitter. FCX-AIII series transmitters with safety function have obtained the certificate of SIL certification by TÜV.

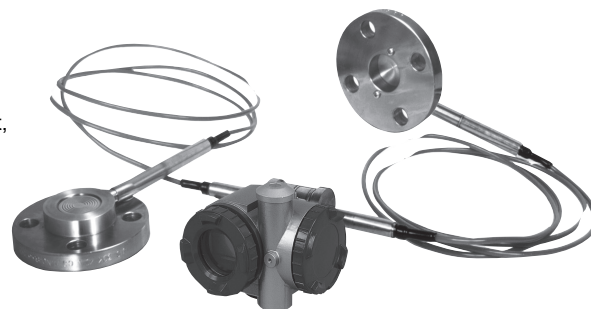

Features

1. It can be directly connected to 1 1/2 inch, 2 inch flange. The transmitter can be mounted on the 1 1/2B, 2B pipe without the reducer union.
2. It's applicable for flow measuring instrument without guide pipe. There're models connected with 1/2B, 3/4B flange, so the measuring instrument system can be constructed without guide pipe. It solves the problem of pipe blockage, leakage, corrosion and so on. Also it can be connected to the following Process Connection:
 - Thread connection Rc 1/2, Rc 3/4, 1/2-14NPT, 3/4-14NPT
3. Excellent environmental adaptability
The advanced floating cell protects sensor from temperature, static pressure and overpressure effect, and controls the total measurement error of the field to the minimum.
4. Excellent operability and easy to use
It has an excellent operability and easy to use in any application.
 - Small and portable remote flange (Flange specification 1 1/2 inch, weight approx. 2.9 kg)
 - 5-digit digital indicator
 - Stainless steel AMP case
 - Built-in RFI filter and lightning arrester
 - Various anti-corrosive materials
 - Products used for high temperature and high vacuum
 - Built-in local configurator with 3 push buttons
5. The transmitter can communicate using FUJI, HART, communication protocol, and also can use FOUNDATION FIELDBUS or PROFIBUS protocol after changing circuit.

Specifications

Functional specifications

- Measured fluid: Liquid, gas, or vapor
- Measuring range:

Model	Span limit [kPa]		Range limit [kPa]	
	Min.	Max.	Lower	Upper
FKX□□3 FDX□□3	0.8	32	-32	32
FKX□□5 FDX□□5	3	130	-130	130
FKX□□6 FDX□□6	12.5	500	-500	500
FKX□□8 FDX□□8	75	3000	-3000	3000

Note: Recommended span should be greater than 1/40 of max. span.

- Operating pressure: Up to max. operating pressure of flange
Thread connection type up to 4.2MPa

- Process temperature, Lower range limit:

Fill fluid	13th digit Code	Process Temperature	Operating pressure
Fluorinated oil	W,A,D	-20 ~ 120°C	Above atmospheric pressure
Silicone oi	H	0 ~ 315°C	
Silicone oi	J	20 ~ 350°C	Above 2.7kPa abs See Figure1
Silicone oi	Y,G	-45 ~ 205°C(Notes)	
Silicone oi	S	0 ~ 250°C	Above atmospheric pressure
Food grade oil(Neobee)	F	-15 ~ 120°C	
Low temperature oil	X	-75 ~ 150°C	

Note: When using plastic coated capillary, temperature range is -45 ~ 120°C.

- Remote function: Refer to table 1

Note: HHC's version must be higher than 7.0 (or FXW□□□□1-□4).

- Output signal: (1)FKX: DC4~20mA+HART protocol
(2)FDX: FOUNDATION Fieldbus protocol or PROFIBUS-PA

- Allowable load resistance: 0 ~ 600Ω (at DC 24V)
(Refer to figure 2) For communication with HHC, min. of 250Ω resistor is required.

- Power supply:

General	DC10.5 ~ 45V
Intrinsic safety	DC10.5 ~ 26V
With arrestor	DC10.5 ~ 32V

- Condition of communication line: Length: up to 2km
(0.75 ~ 1.25mm² Using twisted pair cable when instrument control cable is more than 1km.

Load resistance: 250 ~ 600Ω
(DC24V, including resistance of cable)

Load capacitance: 0.22μF or less

Load inductance: 3.3mH or less

sapcing with power line: 15cm or more
(Please avoid parallel wiring.)

Note: Line condition of intrinsic safety and explosion-proof is different, please refer to the instruction manual.

- Saturation current: Upper limit 20.0 ~ 22.5mA(variable)
Lower limit 3.2 ~ 4.0mA(variable)
(Settable in increments of 0.1mA with HHC or local configurator unit with LCD display.)

- Damping: The time constant is adjustable from 0.06 to 32 seconds.

- Adjustment function: Zero and span are adjustable by the external adjustment screw, or by local configurator with 3 push buttons, or by HHC.

- Zero elevation/suppression: Zero can be elevated or suppressed within the range of -100% to 100% URL.
- Normal/reverse action: Selectable from HHC or LCD unit with local adjustment function.
- Burnout direction: Output hold
Output 20.0 ~ 22.5mA (variable)
Output 3.2 ~ 4.0mA (variable)
(Settable in increments of 0.1mA with HHC or local configurator unit with LCD display.)
- Explosion proof: Refer to table 9
- Ambient temperature: -40 ~ +85°C

With arrester: -40 ~ +60°C
Filling Fluorinated oil: -10 ~ +60°C
Silicone oil H,S: -10 ~ +60°C
Length of capillary is more than 7m: -15 ~ +45°C
Note: The optimum operating temperature of digital indicator is -30 ~ +80°C, response is slow below -30°C.
- Storage temperature: -40 ~ +90°C
- EMC applicable standard: EN61326-1: 2006 (CE)

Performance specifications

Silicone oil fill, SUS316L diaphragms, 4 to 20mA analog output in linear mode.

- Accuracy rating: (including linearity, hysteresis, repeatability) (Standard)
For spans greater than 1/10 of URL:
 $\pm 0.2\%$
For spans below 1/10 of URL:
 $\pm \left(0.1 + 0.1 \frac{0.1 \times \text{URL}}{x} \right) \%$
(Optional) (21th digit code: H,K)
For spans greater than 1/10 of URL:
 $\pm 0.1\%$
For spans below 1/10 of URL:
 $\pm \left(0.05 + 0.05 \frac{0.1 \times \text{URL}}{x} \right) \%$
- Stability: Zero shift $\pm 0.2\%$ of upper range limit (URL) for 10 years.
- Ambient temperature effect: Changed per 28°C in the range of -40°C ~ +85°C.
Zero shift: $\pm 0.5\%/28^\circ\text{C}$
($x \geq 1/2\text{URL}$)
Zero shift: $\pm \left(0.5 \frac{\text{URL}}{2x} \right) \%/28^\circ\text{C}$
($x < 1/2\text{URL}$)
Total shift: $\pm 0.75\%/28^\circ\text{C}$
($x \geq 1/2\text{URL}$)
Total shift: $\pm \left(0.25 + 0.5 \frac{\text{URL}}{2x} \right) \%/28^\circ\text{C}$
($x < 1/2\text{URL}$)
(Optional) (21th digit code: J, K)
Zero shift: $\pm 0.5\%/28^\circ\text{C}$
($x \geq 1/6.5\text{URL}$)
Zero shift: $\pm \left(0.5 \frac{\text{URL}}{6.5x} \right) \%/28^\circ\text{C}$
($x < 1/6.5\text{URL}$)
Total shift: $\pm 0.75\%/28^\circ\text{C}$
($x \geq 1/6.5\text{URL}$)
Total shift: $\pm \left(0.25 + 0.5 \frac{\text{URL}}{6.5x} \right) \%/28^\circ\text{C}$
($x < 1/6.5\text{URL}$)
In the formal: x: SPAN
URL: Upper range limit

- Note: (1) It's the output change when remote flange and transmitter body at the same height and temperature.
(2) When there is temperature difference between remote flange, capillary and transmitter body, the error will increase.
- Unidirectional overrange effect: Zero shift $\pm 0.1\%$ of URL /flange nominal pressure.
In case of 7th digit code(material) is not "V,W,A,B,C,D,E,N,Q,S", the value is 2.5 times of above.
- Static pressure effect: Zero shift $\pm 0.2\%$ of URL /1MPa
In case of 7th digit code(material) is not "V,W,A,B,C,D,E,N,Q,S", the value is 2.5 times of above.
Span shift $\pm 0.2\%$ of SPAN/1MPa
- Overage effect: Zero shift $\pm 0.2\%$ of URL for 1.5×URL
- Supply voltage effect: $\pm 0.005\% /1\text{V}(\text{DC } 16.1 \sim 45\text{V})$
- Insulation strength: 500VAC, 50/60Hz, 1 min, between circuit and earth.
- Insulation resistance: More than 100MΩ at 500V DC, between circuit and earth.
- Update rate: 60ms
- Response time: Time constant: 1.7s
(Capillary length: 1.5m, at 23°C)
Dead time: approx. 0.12s
The response time is long when the capillary length is more than 6m.
The response time increased about 1.7s per 1.5m extending, at 23°C.

Structure and material

- Flange materials: SUS304、SUS316 or carbon steel
- Detecting unit materials:

Material code	Seal diaphragm	Other wetted parts
V,A,B,C,D	SUS316L	SUS316
E、N、Q、S	SUS316L	SUS304
W	Hastelloy-C	SUS316
J, 5, 6, 7, 8	SUS316L Gold-plated	SUS316
H, F, G, K, L	Hastelloy-C	Hastelloy-C
M	Monel	Monel
T, 1, 2, 3, 4	Tantalum	Tantalum

- Amp case materials: Aluminium die casting + Polyester coating (color: silvery) or Stainless steel(SCS14A)
- Amp case cover materials: Aluminium die casting + Polyester coating (color: blue) or Stainless steel(SCS14A)
- Structure of case: Immersion protected type JIS C 0920 (Equivalent to IEC IP67, NEMA 6/6P)
- Outline dimension: According to the outline drawing.
- Weight: approx. 5~13kg
- Conduit connection: G¹/₂, 1/2-14NPT, M20× 1.5, Pg13.5 (Refer to the model code table for details.)
- External terminal: M3.5 Screw
- Preprocess connection:
JIS standard
(Please refer to the model code for details.)
10K,20K,30K, 63K - 40,50A
10K,20K,30K - 15,20A
(with adapter)
ANSI/JPI standard
150LB, 300LB, 600LB - 1¹/₂B,2B
150LB, 300LB - 1¹/₂B, 3³/₄B
(with adapter)
GB/T/HG standard
PN10, PN20, PN40, PN50,
- DN40, DN50
Thread connection (with adapter)
Rc¹/₂, Rc³/₄, 1/2-14NPT, 3/4-14NPT
- Diaphragm Extension length: 0, 50, 100, 150, 200mm (according to the specified)

- Mounting method: Mounting on 50A(2B) pipe with U-bolt, detecting part mounting with flange, flange clamping method (sheet type), thread connection(with adapter).
- Direction of AMP unit: Amp unit can be turned clockwise or counterclockwise by 90° or 180°, relative to the direction of detecting unit.
- Length of capillary: Max 15m
 (When the length is more than 7m and silicone oil is "H,J", the ambient temperature is below +45°C.)
- Wrapping material of capillary: Plastic coated or stainless steel hose

Optional specifications

- Analog indicator: Built in amplifier unit
 Class 2.5, moving-coil, movement 90°, 0 ~ 100% evenly divided or actual scale
- Digital indicator: Built in amplifier unit, 5 digit LCD and unit display, 0 ~ 100% scale display, actual scale display or 0 ~ 100% square root display. Optimum operating temperature range: -30 ~ +80°C.
- Digital indicator: Displaying or setting the items of table 1 (with 3 push buttons) via 3 push buttons of digital indicator.
- Arrester: Built in amplifier unit
 Lightning performance: 4kV(1.2× 50μs)
- Degreasing treatment for oxygen: Filling fluorinated oil, degreasing and cleaning for wetted parts, available only for 7th digit code (material) "V,W,A,B,C,D,E,N,Q,S".
- Chlorine measurement: Filling fluorinated oil, available only for 7th digit code (material) "H,T".
- Anti-corrosive coating of detecting unit: Epoxy and polyurethane double coating
- Stainless steel tag plate: The plate can be engraved up to 14 characters (letters and numbers)

Table1 Adjustment function

No.	Items	HHC (Model:FXW) ^{Note1)}		Local configurator (With 3 push buttons)	
		Display	Set	Display	Set
1	Tag No.	○	○	○	○
2	Type	○	○	○	○
3	Serial No. & Software Version	○	—	○	—
4	Engineering unit	○	○	○	○
5	Range Limit	○	—	○	—
6	Measuring range	○	○	○	○
7	Damping	○	○	○	○
8	Output mode	○	—	○	—
9	Burnout direction	○	○	○	○
A	Zero/span calibration	○	○	○	○
B	Calibration of output circuit	—	○	—	○
C	Measured data	○	—	○	—
D	Self-diagnosis	○	—	○	—
E	Printer function	○	—	—	—
F	Lock of adj. function	○	○	○	○
G	Indication of digital indicator	○	○	○	○
H	Linearize	○	○	—	—
I	Rerange	○	○	○	○
J	Saturation current Write	○	○	○	○
K	protect	○	○	○	○
L	History				
	-Calibration history	○	○	○	○
	-Temperature history	○	—	○	—

Note1) The version of HHC must be higher than 7.0 when it supports FCX-All series transmitter(or FXW□□□□1-□4).
 It can upgrade the version by changing ROM, please consult our company's windows or agency shop nearby for details.

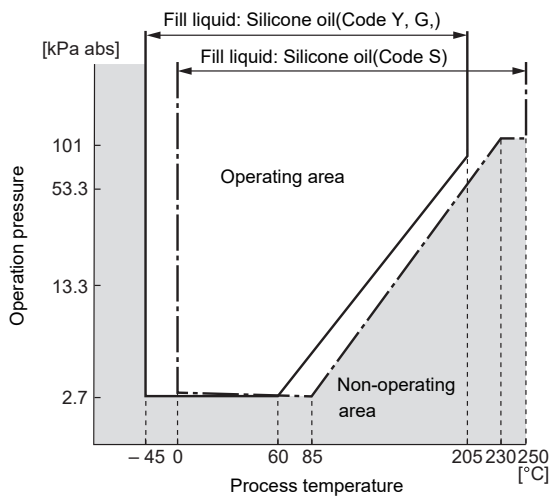

Note: When using the transmitter in a vacuum area, locate it lower than the flange.

Figure 1 Relation between process temperature and operating pressure

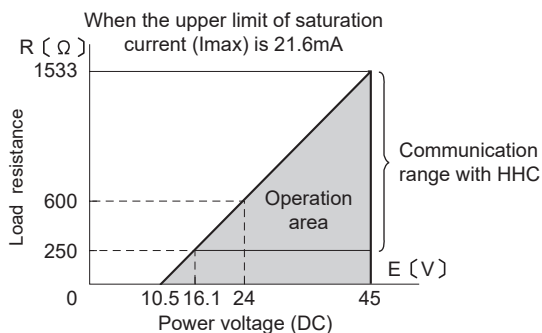

(Note) The load resistance varies according to the upper limit of saturation current.

$$R (\Omega) = \frac{E (V) - 10.5}{(I_{max} (mA) + 0.9) \times 10^{-3}}$$

Figure 2 Operation area of power voltage and load resistance

Scope of delivery

Instrument body, pipe mounting bracket (according to type selection)

Related products

- Hand held communicator (Model: FXW):
 Hand held, built-in battery, setting, display
 For the details, please refer to data sheet (CSDS8-47).

Ordering information

1. Model code
2. Span
3. Please select the direction of output (Notuse/OVER/UNDER) when the transmitter is fault (Burnout). If unspecified, it is Notuse.
4. Please select the output mode (linear or square root). If unspecified, it is linear mode.
5. If the scale of indicator is selected to actual scale (9th code: D,H,P,S), please select the items of display (digit, scale, unit, etc).
6. Please select the tag plate according to need.(up to 14 digit, consist of letters and numbers).



It's type of connecting pipeless adapter (15A, 20A, 1/2B, 3/4B for connecting) and model discription of chinese standard flange, from 16th to 20th digit code.

Digit	Discription	Note	9	10	11	12	13	14	15	16	17	18	19	20	21	22
	Small flange remote seal type differential pressure transmitter DC4~20mA+HART FOUNDATION Fieldbus and PROFIBUS		FKX			5				0						
			FDX			5				0						
16	<Process connection>	<Flange materials>														
17	JIS 10K 15A	SUS316										1				
18	JIS 10K 20A	SUS316										2				
	JIS 20K 15A	SUS316										2				
	JIS 20K 20A	SUS316										2				
	JIS 30K 15A	SUS316										3				
	JIS 30K 20A	SUS316										3				
	ANSI/JPI 150LB 1/2B	SUS316										1				
	ANSI/JPI 150LB 3/4B	SUS316										1				
	ANSI/JPI 300LB 1/2B	SUS316										2				
	ANSI/JPI 300LB 3/4B	SUS316										2				
	Thread connection Rc1/2	SUS316										S				
	Thread connection Rc3/4	SUS316										S				
	Thread connection 1/2-14NPT	SUS316										S				
	Thread connection 3/4-14NPT	SUS316										S				
	GB/T/ HG DN40 PN10/16	Carbon steel	Note20									B				
	GB/T/ HG DN40 PN10/16	SUS304	Note20									B				
	GB/T/ HG DN40 PN10/16	SUS316	Note20									B				
	GB/T/ HG DN40 PN20(class 150)	Carbon steel	Note20									C				
	GB/T/ HG DN40 PN20(class 150)	SUS304	Note20									C				
	GB/T/ HG DN40 PN20(class 150)	SUS316	Note20									C				
	GB/T/ HG DN40 PN50(class 300)	Carbon steel	Note20									D				
	GB/T/ HG DN40 PN50(class 300)	SUS304	Note20									D				
	GB/T/ HG DN40 PN50(class 300)	SUS316	Note20									D				
	GB/T/ HG DN40 PN25/40	Carbon steel	Note20									E				
	GB/T/ HG DN40 PN25/40	SUS304	Note20									E				
	GB/T/ HG DN40 PN25/40	SUS316	Note20									E				
	GB/T/ HG DN40 PN63	Carbon steel	Note20									F				
	GB/T/ HG DN40 PN63	SUS304	Note20									F				
	GB/T/ HG DN40 PN63	SUS316	Note20									F				
	GB/T/ HG DN40 PN100	Carbon steel	Note20									G				
	GB/T/ HG DN40 PN100	SUS304	Note20									G				
	GB/T/ HG DN40 PN100	SUS316	Note20									G				
	GB/T/ HG DN50 PN10/16	Carbon steel	Note20									B				
	GB/T/ HG DN50 PN10/16	SUS304	Note20									B				
	GB/T/ HG DN50 PN10/16	SUS316	Note20									B				
	GB/T/ HG DN50 PN20(class 150)	Carbon steel	Note20									C				
	GB/T/ HG DN50 PN20(class 150)	SUS304	Note20									C				
	GB/T/ HG DN50 PN20(class 150)	SUS316	Note20									C				
	GB/T/ HG DN50 PN50(class 300)	Carbon steel	Note20									D				
	GB/T/ HG DN50 PN50(class 300)	SUS304	Note20									D				
	GB/T/ HG DN50 PN50(class 300)	SUS316	Note20									D				
	GB/T/ HG DN50 PN25/40	Carbon steel	Note20									E				
	GB/T/ HG DN50 PN25/40	SUS304	Note20									E				
	GB/T/ HG DN50 PN25/40	SUS316	Note20									E				
	GB/T/ HG DN50 PN63	Carbon steel	Note20									F				
	GB/T/ HG DN50 PN63	SUS304	Note20									F				
	GB/T/ HG DN50 PN63	SUS316	Note20									F				
	GB/T/ HG DN50 PN100	Carbon steel	Note20									G				
	GB/T/ HG DN50 PN100	SUS304	Note20									G				
	GB/T/ HG DN50 PN100	SUS316	Note20									G				
	ANSI 150LB 1 1/2B	SUS316	Note23									H				
	ANSI 300LB 1 1/2B	SUS316	Note23									J				
	ANSI 600LB 1 1/2B	SUS316	Note23									K				
	ANSI 150LB 2B	SUS316	Note23									H				
	ANSI 300LB 2B	SUS316	Note23									J				
	ANSI 600LB 2B	SUS316	Note23									K				
19	<Vent/drain(for connecting pipeless apapter)> Standard(Rc1/4)		Note22										A			
20	<Gasket> Standard(Teflon) For high temperature(spiral gasket)		Note22 Note8 Note9											1 2		
21	<Other> None High accuracy type Low temperature type H+J Inspection report		Note10												Y H J K F	
22	<Flush ring> Yes None Yes	<Companion flange> None Yes Yes	Note10													A B C

- Note1) For using connecting pipeless adapter, please be sure to select 16th to 20th digit code. The 7th digit code only "V" can be selected.
- Note2) Available only for 50A, 2B, DN50 flange.
- Note3) Not available for square root mode.
- Note4) Available only for 7th digit code "V,A,B,C,D,E,N,Q,S".
- Note5) Available only for 7th digit code "H,T".
- Note6) Available only for 7th digit code "V,A,B,C,D,E,N,Q,S,H".
- Note6) Not available for 7th digit code "A,B,C,D,E,N,Q,S", 5th digit code "Y", and 13th digit code "H,S".
- The operating pressure and temperature for using teflon diaphragm:
- Atmospheric pressure~max. operating pressure of flange(not available for vacuum)
 - 0 ~ 120° C
- Note7) Available only for 13th digit code "Y,W,G,A,D". Not available for 13th digit code "H,S".
- Note9) Available only for 13th digit code "H,S".
- Note10) The digit is blank when not needed.
- Note11) Not available for 10th digit code "C".

- Note12) The ultra thick diaphragm is for the requirements of wear resistance or process condition of solid particle erosion.
 Note13) Other standard flanges are available.
 Note14) For specific specifications, please refer to 16th to 19th digit code. RTJ flange is only available for 7th digit code "V,J"
 Note15) Please note when select Fieldbus or Profibus transmitter. (Under development)
 Note17) Available only for 4th digit code "5,S".
 Note18) Available only for 4th digit code "6,8,T,W".
 Note19) Available only for 4th digit code "6,T".

- Note20) Please specify the flange specifications at "16th,17th,18th" digit code, when 5th digit code "9"(Chinese flange).
 Note21) For unequal length capillary, it should be carried out according to the principle as follow: high pressure side in the front and low pressure side in the back, separated by "/" in the middle , the 11th digit code is 2 characters. For example, if using the plastic-coated capillary, high pressure side length is 3m, low pressure side length is 5m, then 11th digit code is "E/L".
 Note22) The digit is blank when 5th digit code "8,9".
 Note23) Please specify the flange specifications at "16th,17th,18th" digit code, when 5th digit code "8"(ANSI standard SUS316 flange).

<Facing type is ring joint face(RTJ)>

Digit	Discriptions	Note	1	2	3	4	5	6	7	8	9	10	11	12	13	14	15	16	17	18	19	20	21	
16	Mounting flange		F	X			5									0								
17	<Materials>	<Specifications>																						
	304 Stainless steel	ANSI/JPI 600LB 1 1/2B																						
		ANSI/JPI 600LB 2B																						
		ANSI/JPI 900LB/1500LB 1 1/2B																						
		ANSI/JPI 900LB/1500LB 2B																						
		ANSI/JPI 2500LB 1 1/2B																						
		ANSI/JPI 2500LB 2B																						
	316 Stainless steel	ANSI/JPI 600LB 1 1/2B																						
		ANSI/JPI 600LB 2B																						
		ANSI/JPI 900LB/1500LB 1 1/2B																						
		ANSI/JPI 900LB/1500LB 2B																						
		ANSI/JPI 2500LB 1 1/2B																						
		ANSI/JPI 2500LB 2B																						
	Carbon steel	ANSI/JPI 600LB 1 1/2B																						
		ANSI/JPI 600LB 2B																						
		ANSI/JPI 900LB/1500LB 1 1/2B																						
		ANSI/JPI 900LB/1500LB 2B																						
		ANSI/JPI 2500LB 1 1/2B																						
		ANSI/JPI 2500LB 2B																						
	Without flange (disc type)	ANSI/JPI 600LB 1 1/2B																						
		ANSI/JPI 600LB 2B																						
		ANSI/JPI 900LB/1500LB 1 1/2B																						
		ANSI/JPI 900LB/1500LB 2B																						
		ANSI/JPI 2500LB 1 1/2B																						
		ANSI/JPI 2500LB 2B																						
18	<Gasket(applicable for RTJ)> None Yes																							
19	<Companion flange> None Yes																							
20	<Fixed code>																							
21	<Fixed code>																							

Note)When ordering the transmitters with high pressure flange and the facing type is ring joint face(RTJ), the 5th digit code is "I", and should specify the 16th, 17th, 18th, 19th digit code.

The product conforms to the requirements of European EMC directive "Electromagnetic Compatibility Directive2004/108/EC". The detail content is recorded in the technical construction file number TN5A0704. The applicable standards are as follows:

Emission list:

EN 61326-1 : 2006 Class A (Industrial location)



Frequency range	Limits	Reference standard
30 ~ 230MHz	40dB(µV/m) quasi peak, measured at 10m distance	EN55011:1998 +A1:1999
230 ~ 1000MHz	47dB(µV/m) quasi peak, measured at 10m distance	+A2:2002 (Group1 Class A)

Immunity requirements:

EN 61326-1 : 2006 Table2 (Industrial location)

Phenomenon	Test value	Basic standard	P.C.
Electrostatic discharge	2/4kV (Contact) 2/4/8kV (Air)	IEC 61000-4-2:1995 +A1:1998+A2:2001	B
Electromagnetic field	10V/m(80 ~ 1000MHz) 3V/m(1.4 ~ 2.0GHz) 1V/m(2.0 ~ 2.7GHz) 80%AM(1kHz)	IEC 61000-4-3:2002 +A1:2002	A
Rated power frequency magnetic field	30 A/m 50/60 Hz	IEC 61000-4-8:1993 +A1:2001	A
Burst	2kV	IEC 61000-4-4:2004	B
Surge	1.2/50µs(Voltage) 8.0/20µs(Current) 0.5/1kV line to line 0.5/1/2kV line to ground	IEC 61000-4-5:1995 +A1:2001	B
Conducted RF	0.15 ~ 80MHz 3V 80%AM(1kHz)	IEC 61000-4-6:1996 +A1:2001	A

Definition of performance criteria:

- A: During testing, normal performance within the specification limits.
 B: During testing, temporary degradation, or less of function or performance which is self-recovering.

Note24) The 8th digit code can be selected as "S", this means that it's the transmitter with safety function. SIL2 capability for single transmitter use, SIL3 capability for dual transmitter use.

FKX

OUTLINE DIAGRAM (Unit: mm)

<AMP. CASE: L TYPE>

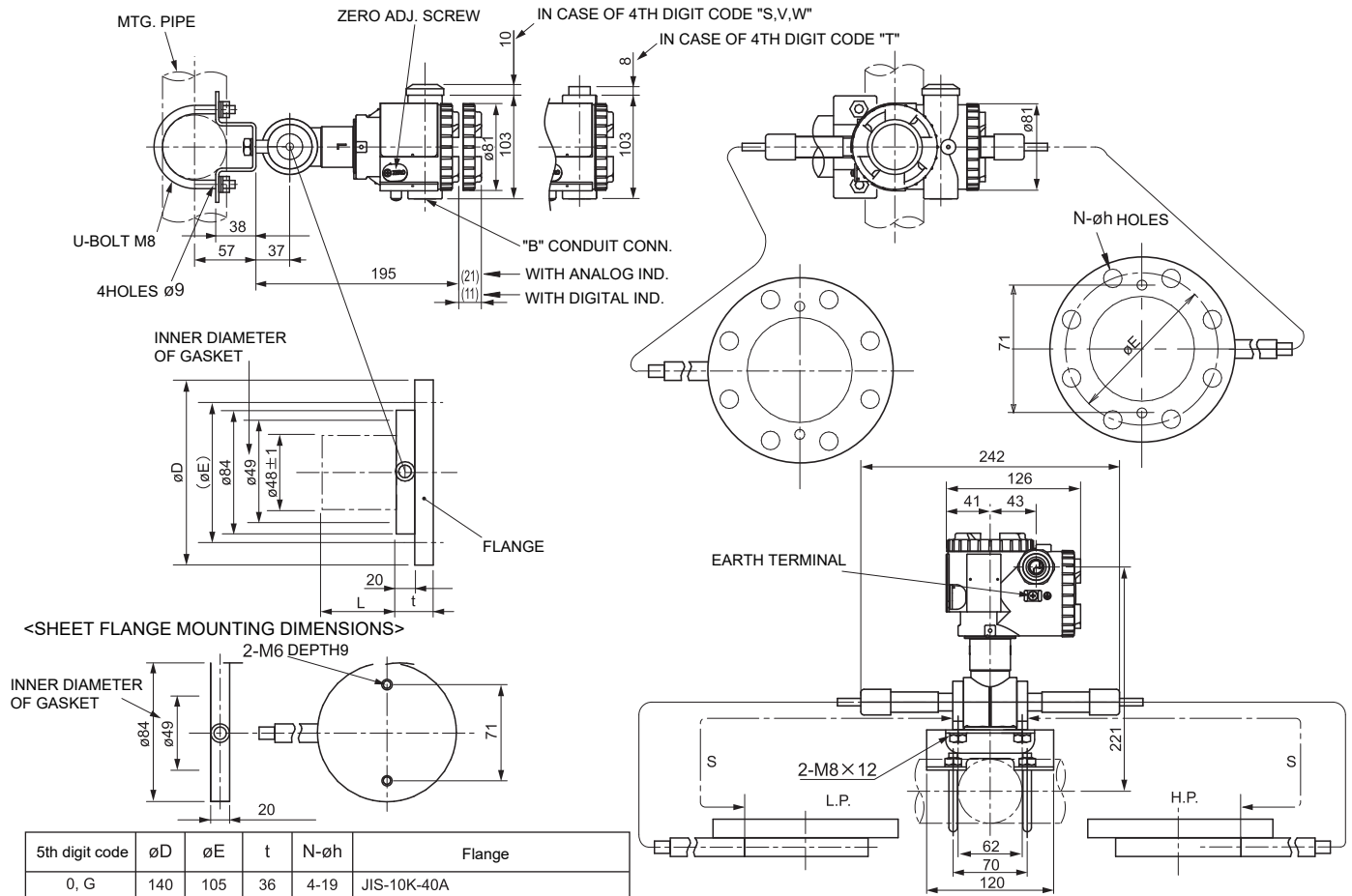

5th digit code	øD	øE	t	N-øh	Flange
0, G	140	105	36	4-19	JIS-10K-40A
1, H	155	120	36	4-19	JIS-10K-50A
2, J	140	105	38	4-19	JIS-20K-40A
3, K	155	120	38	8-19	JIS-20K-50A
4, L	160	120	42	4-23	JIS-30K-40A
5, M	165	130	42	8-19	JIS-30K-50A
6, N	175	130	52	4-25	JIS-63K-40A
7, P	185	145	54	8-23	JIS-63K-50A
A, Q	127	98.4	37.5	4-16	ANSI/JPI-150LB-1 1/2B
B, R	152	120.6	39.5	4-20	ANSI/JPI-150LB-2B
C, S	156	114.3	41	4-23	ANSI/JPI-300LB-1 1/2B
D, T	165	127	42.5	8-20	ANSI/JPI-300LB-2B
E, U	156	114.3	42.5	4-23	ANSI/JPI-600LB-1 1/2B
F, V	165	127	45.5	8-20	ANSI/JPI-600LB-2B

16th to 18th digit code	øD	øE	t	N-øh	Flange
B4C,B4U,B4W	150	110	38	4-18	GB/T / HG DN40 PN10/16
C4C,C4U,C4W	130	98.5	37.5	4-16	GB/T / HG DN40 PN20
E4C,E4U,E4W	150	110	38	4-18	GB/T / HG DN40 PN25/40
D4C,D4U,D4W	155	114.5	41	4-22	GB/T / HG DN40 PN50
F4C,F4U,F4W	170	125	46	4-22	GB/T / HG DN40 PN63
G4C,G4U,G4W	170	125	46	4-22	GB/T / HG DN40 PN100
B5C,B5U,B5W	165	125	40	4-18	GB/T / HG DN50 PN10/16
C5C,C5U,C5W	150	120.5	39.5	4-18	GB/T / HG DN50 PN20
E5C,E5U,E5W	165	125	40	4-18	GB/T / HG DN50 PN25/40
D5C,D5U,D5W	165	127	42.5	8-18	GB/T / HG DN50 PN50
F5C,F5U,F5W	180	135	46	4-22	GB/T / HG DN50 PN63
G5C,G5U,G5W	195	145	48	4-26	GB/T / HG DN50 PN100
H4W	127	98.4	37.5	4-16	ANSI 150LB 11/2B
J4W	156	114.3	41	4-23	ANSI 300LB 11/2B
K4W	156	114.3	42.5	4-23	ANSI 600LB 11/2B
H5W	152	120.6	39.5	4-20	ANSI 150LB 2B
J5W	165	127	42.5	8-20	ANSI 300LB 2B
K5W	165	127	42.5	8-20	ANSI 600LB 2B

7th digit code	L	Weight(kg)
V, J, H, M, T, W	0	12.7 ~ 18.2
A, E	50	13.7 ~ 29.2
B, N	100	14.2 ~ 29.7
C, Q	150	14.7 ~ 30.2
D, S	200	15.2 ~ 30.7

11th digit code	Capillary length S (m)
D, Q	1.5
E, R	3
L, S	5
F, T	6
M, V	7
N, W	8
P, X	10
G, J	12
H, K	15

4th digit code	Conduit conn.		
	J	K	M
S	G1/2	18	2
T	1/2-14NPT	16	4
V	Pg13.5	10.5	4.5
W	M20×1.5	16	4

TABLE2

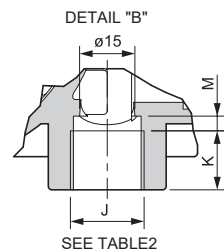

<SS TAG PLATE(OPTIONAL)> <CONNECTION DIAGRAM>

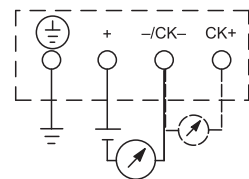
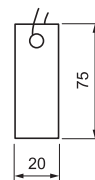

<OPTIONAL PARTS FOR FLAMEPROOF OF TIIS> (OMITTED)

<AMP. CASE: L TYPE>WITH CONNECTING PIPELESS ADAPTER(THREAD CONNECTION TYPE)

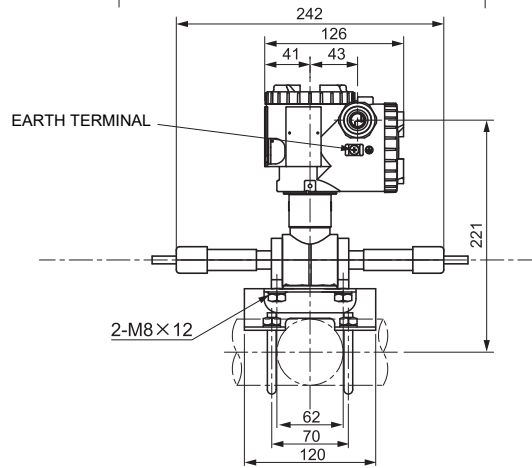
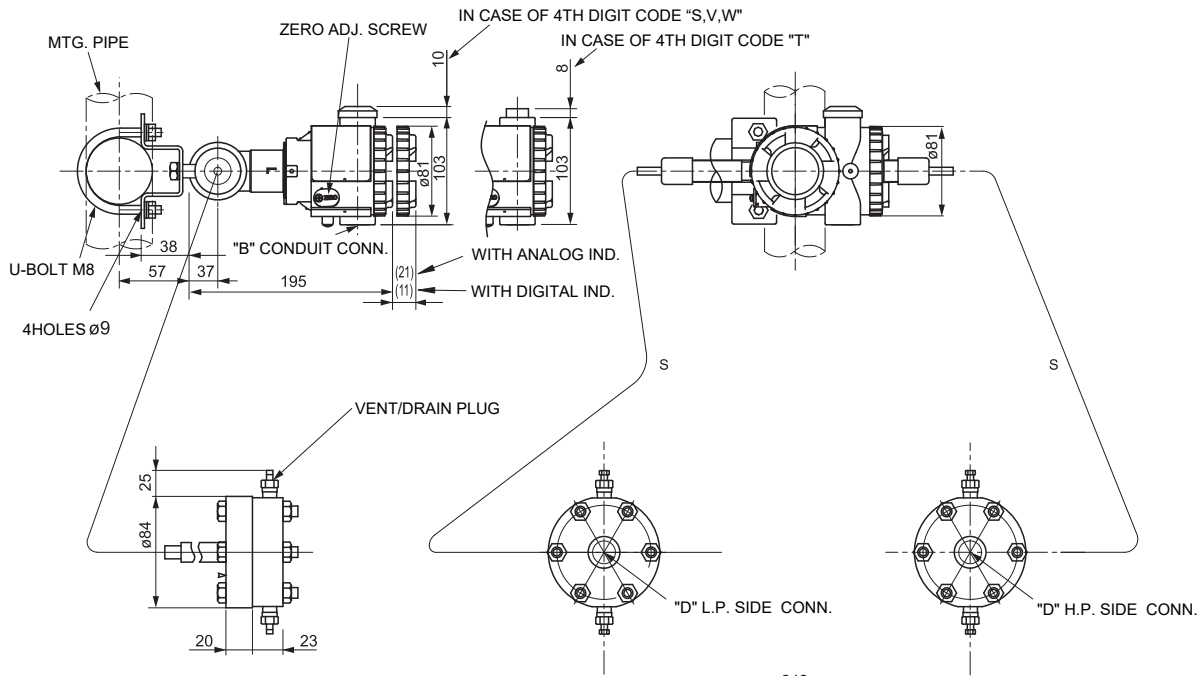

16th digit code	17th digit code	"D" precess conn.
S	R	Rc 1/2
S	N	1/2-14NPT
S	2	Rc 3/4
S	T	3/4-14NPT

4th digit code	Conduit conn.		
	J	K	M
S	G1/2	18	2
T	1/2-14NPT	16	4
V	Pg13.5	10.5	4.5
W	M20 x 1.5	16	4

TABLE 4

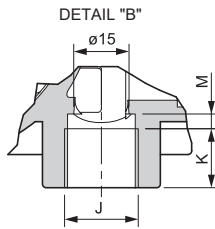

SEE TABLE 4

11th digit code	S (m)
D, Q	1.5
E, R	3
L, S	5
F, T	6
M, V	7
N, W	8
P, X	10
G, J	12
H, K	15

<OPTIONAL PARTS FOR FLAMEPROOF OF TIIS>

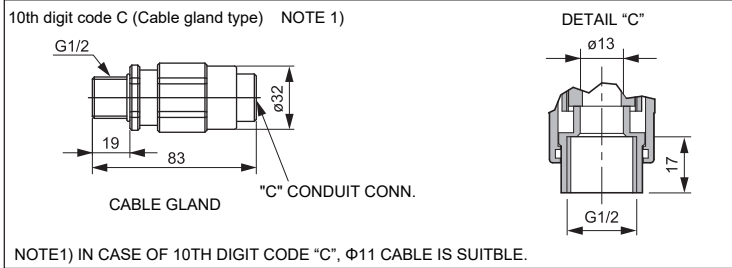

<SS TAG PLATE(OPTIONAL)> <CONNECTION DIAGRAM>

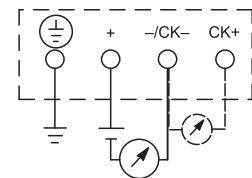
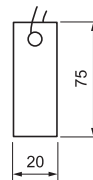

<AMP. CASE: T TYPE>WITH CONNECTING PIPELESS ADAPTER(THREAD CONNECTION TYPE)

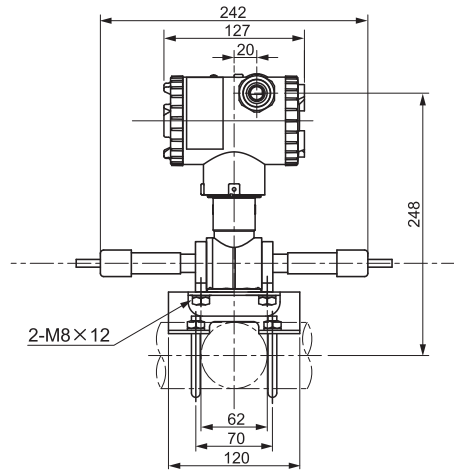
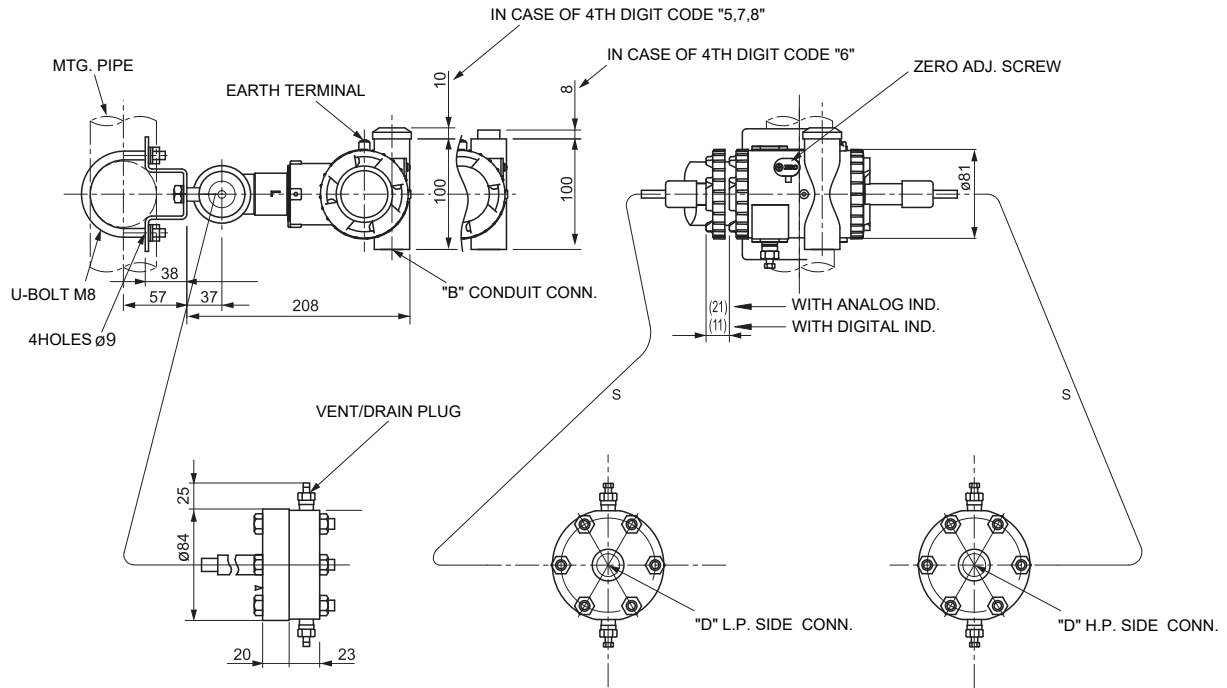

16th digit code	17th digit code	"D" precess conn.
S	R	Rc 1/2
S	N	1/2-14NPT
S	2	Rc 3/4
S	T	3/4-14NPT

4th digit code	Conduit conn.		
	J	K	M
5	G1/2	18	2
6	1/2-14NPT	16	4
7	Pg13.5	10.5	4.5
8	M20 x 1.5	16	4

TABLE5

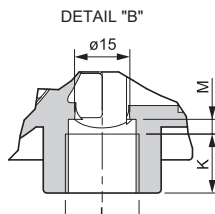

SEE TABLE5

11th digit code	S (m)
D, Q	1.5
E, R	3
L, S	5
F, T	6
M, V	7
N, W	8
P, X	10
G, J	12
H, K	15

<OPTIONAL PARTS FOR FLAMEPROOF OF TIIS>

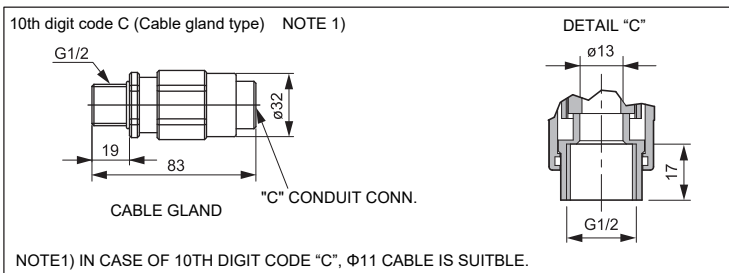

<SS TAG PLATE(OPTIONAL)> <CONNECTION DIAGRAM>

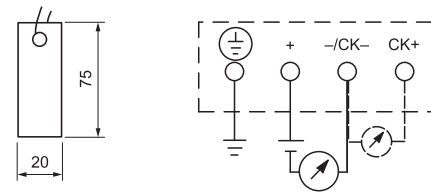

FKX

<AMP. CASE: L TYPE>WITH FLANGE

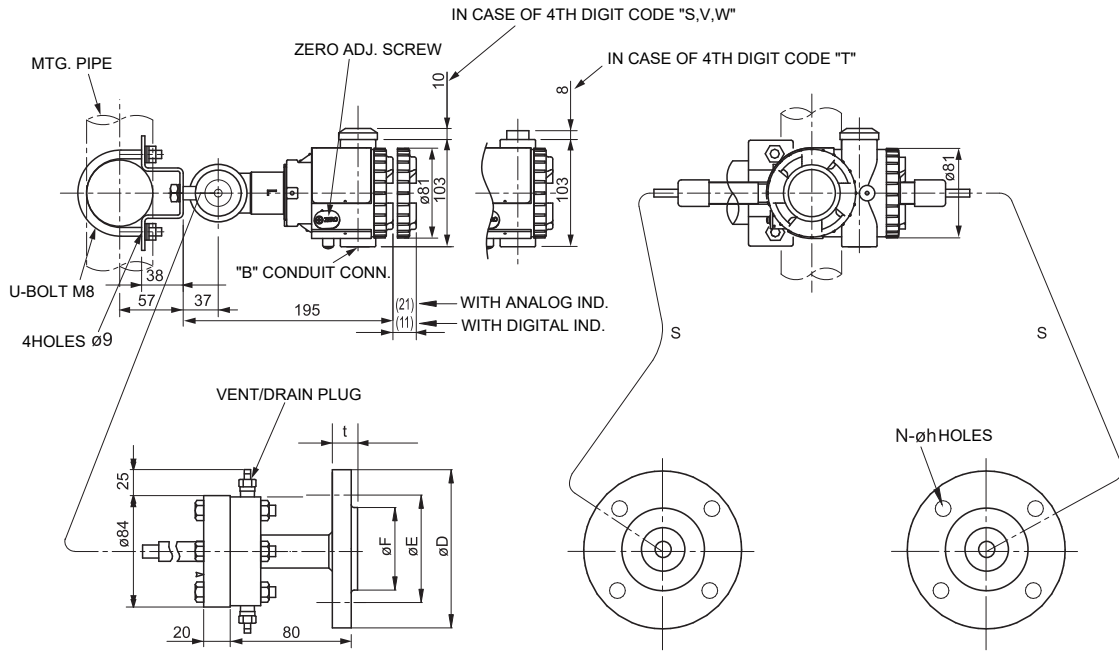

16th digit code	17th digit code	øD	øE	øF	t	N-øh	Flange
1	1	95	70	51	12	4-15	JIS-10K-15A
1	2	100	75	56	14	4-15	JIS-10K-20A
2	1	95	70	51	14	4-15	JIS-20K-15A
2	2	100	75	56	16	4-15	JIS-20K-20A
3	1	115	80	55	18	4-19	JIS-30K-15A
3	2	120	85	60	18	4-19	JIS-30K-20A
1	H	89	60.3	34.9	11.5	4-16	ANSI/JPI-150LB-1/2B
1	T	98	69.9	42.9	13	4-16	ANSI/JPI-150LB-3/4B
2	H	95	66.7	34.9	14.5	4-16	ANSI/JPI-300LB-1/2B
2	T	117	82.5	42.9	16	4-20	ANSI/JPI-300LB-3/4B

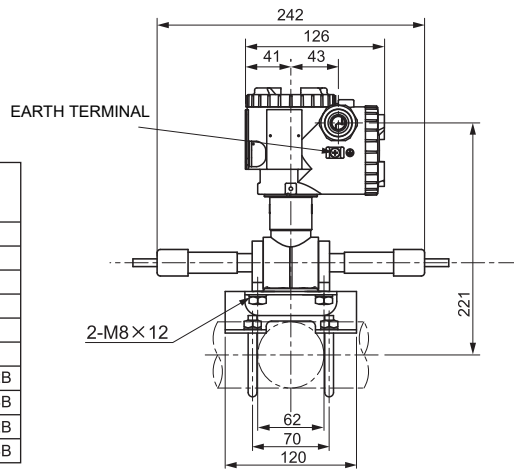

4th digit code	Conduit conn.		
	J	K	M
S	G1/2	18	2
T	1/2-14NPT	16	4
V	Pg13.5	10.5	4.5
W	M20x1.5	16	4

TABLE6

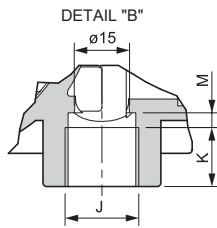

SEE TABLE6

11th digit code	S (m)
D, Q	1.5
E, R	3
L, S	5
F, T	6
M, V	7
N, W	8
P, X	10
G, J	12
H, K	15

<OPTIONAL PARTS FOR FLAMEPROOF OF TIIS>

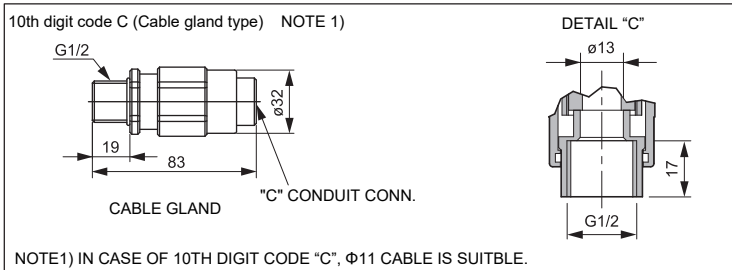

<SS TAG PLATE(OPTIONAL)> <CONNECTION DIAGRAM>

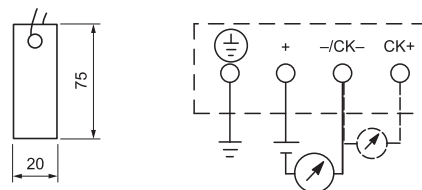

<AMP. CASE: T TYPE>WITH FLANGE

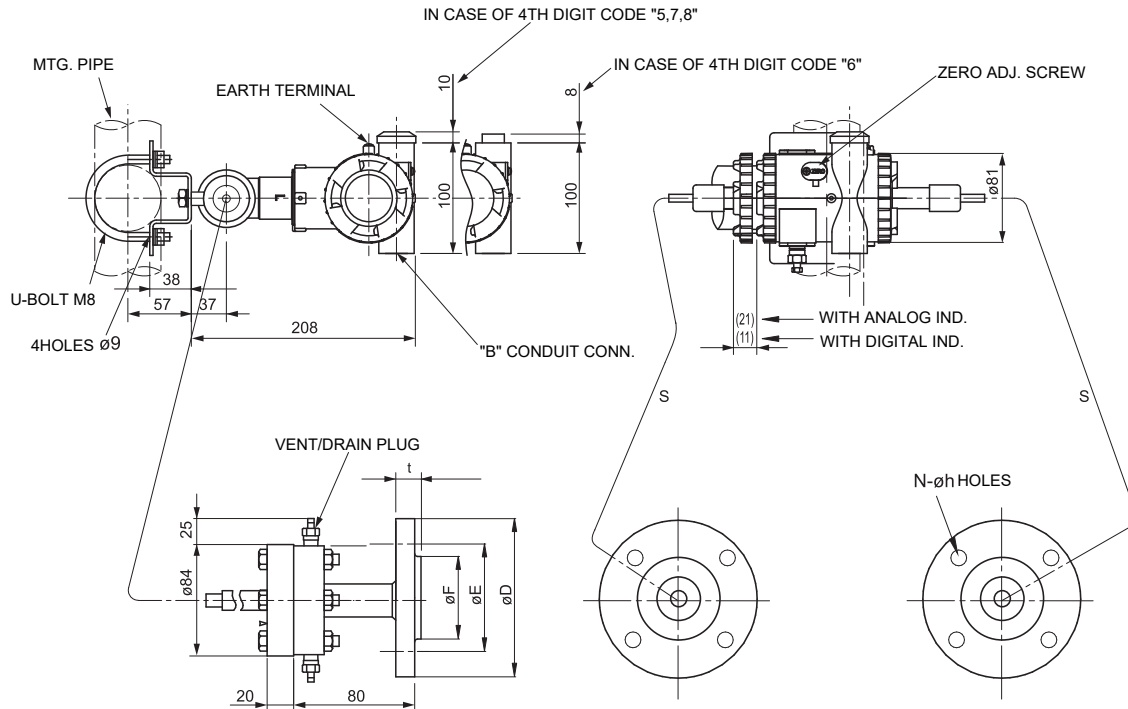

16th digit code	17th digit code	øD	øE	øF	t	N-øh	Flange
1	1	95	70	51	12	4-15	JIS-10K-15A
1	2	100	75	56	14	4-15	JIS-10K-20A
2	1	95	70	51	14	4-15	JIS-20K-15A
2	2	100	75	56	16	4-15	JIS-20K-20A
3	1	115	80	55	18	4-19	JIS-30K-15A
3	2	120	85	60	18	4-19	JIS-30K-20A
1	H	89	60.3	34.9	11.5	4-16	ANSI/JPI-150LB-1/2B
1	T	98	69.9	42.9	13	4-16	ANSI/JPI-150LB-3/4B
2	H	95	66.7	34.9	14.5	4-16	ANSI/JPI-300LB-1/2B
2	T	117	82.5	42.9	16	4-20	ANSI/JPI-300LB-3/4B

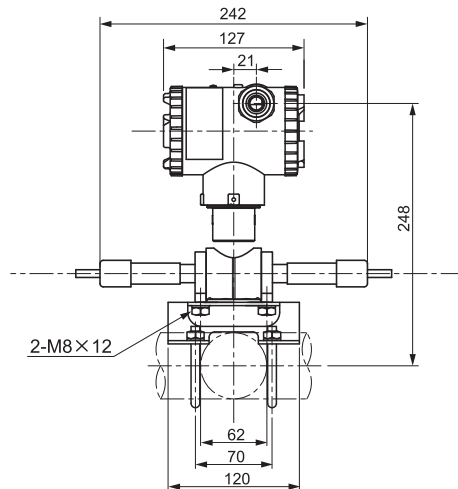

4th digit code	Conduit conn.		
	J	K	M
5	G1/2	18	2
6	1/2-14NPT	16	4
7	Pg13.5	10.5	4.5
8	M20x1.5	16	4

TABLE7

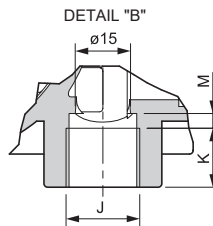

SEE TABLE7

11th digit code	S (m)
D, Q	1.5
E, R	3
L, S	5
F, T	6
M, V	7
N, W	8
P, X	10
G, J	12
H, K	15

<OPTIONAL PARTS FOR FLAMEPROOF OF TIIS>

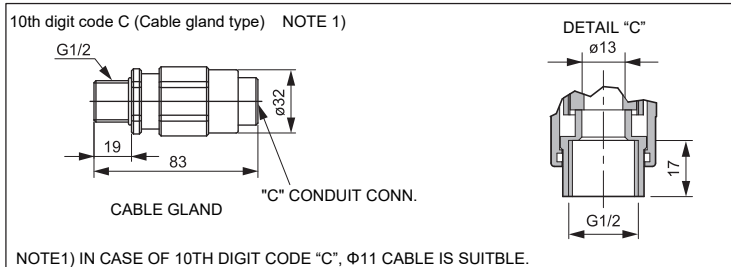

<SS TAG PLATE(OPTIONAL)> <CONNECTION DIAGRAM>

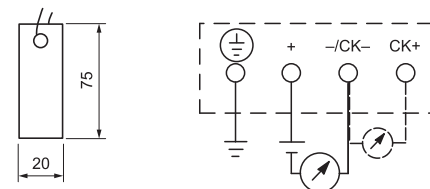

FKX

<FACING TYPE OF FLANGE IS RING JOINT FACE(RTJ)>

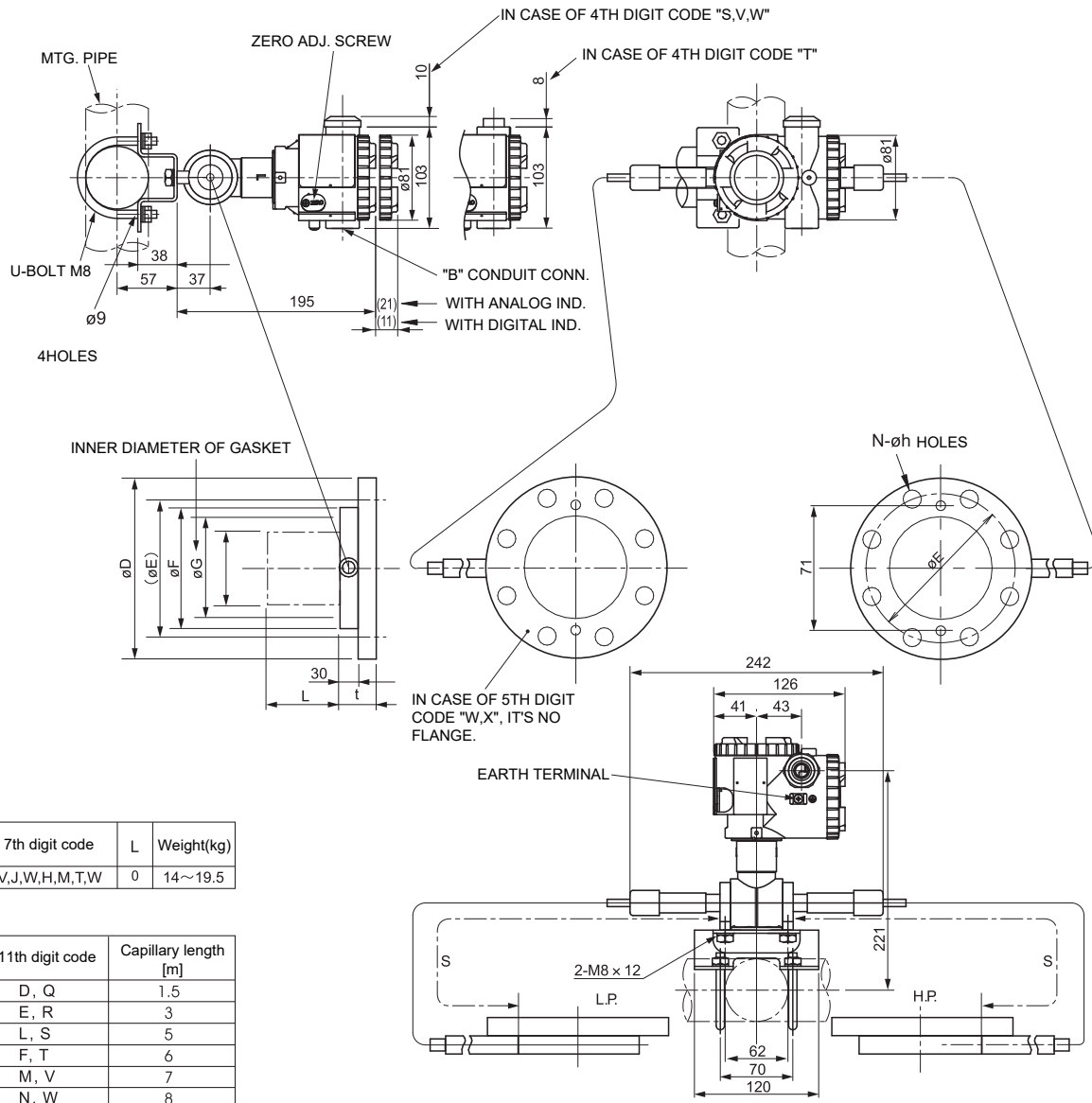

7th digit code	L	Weight(kg)
V,J,W,H,M,T,W	0	14~19.5

11th digit code	Capillary length [m]
D, Q	1.5
E, R	3
L, S	5
F, T	6
M, V	7
N, W	8
P, X	10
G, J	12
H, K	15

16th, 17th digit code	øD	øE	øF	øG	øH	t	n-øh	Flange specification
41,51,61	156	114.3	90.5	68.28	48	52.5	4-23	ANSI 600LB 1 1/2 B
42,52,62	165	127	106	82.55	48	55.5	8-20	ANSI 600LB 2B
43,81,91	178	124	92	68.28	48	62	4-28	ANSI 900/1500LB 1 1/2 B
44,82,92	216	165	124	95.25	48	68.5	8-26	ANSI 900/1500LB 2B
45,11,21	203	146	114	82.55	48	74.5	4-32	ANSI 2500LB 1 1/2 B
46,12,22	235	171.5	133	101.60	48	81	8-30	ANSI 2500LB 2B

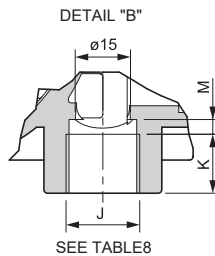

4th digit code	Conduit conn.		
	J	K	M
5,S	G1/2	17	8
6,T	1/2-14NPT	16	5
7,V	Pg13.5	8	4.5
8,W	M20x1.5	16	5

TABLE8

<OPTIONAL PARTS FOR FLAMEPROOF OF TIIS>

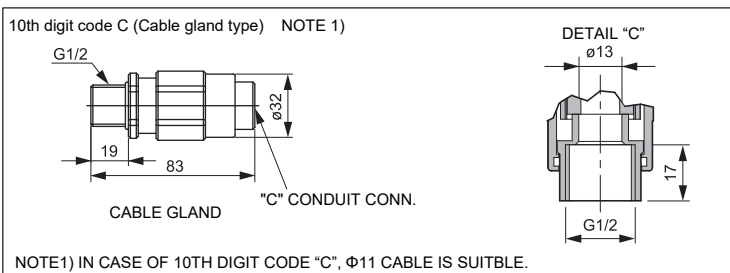

<SS TAG PLATE(OPTIONAL)> <CONNECTION DIAGRAM>

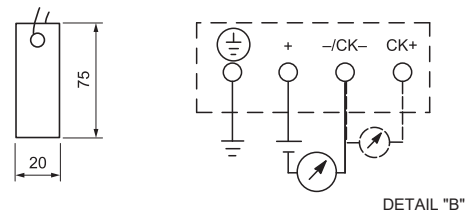

DETAIL "B"

<The facing dimensions of ring joint face(RTJ) flange>

No.	16th, 17th digit code	ΦF	Seal groove dimensions				ΦH	P	Flange specifications
			Pitch diameter Φ(G)	Depth(E)	Width(F)	Radius(R)			
1	01	90.5	68.28	6.35	8.74	0.76	48	71	ANSI 600LB 1½B
2	02	106	82.55	7.92	11.91	0.76	48	71	ANSI 600LB 2B
3	03	92	68.28	6.35	8.74	0.76	48	71	ANSI 900/1500LB 1½B
4	04	124	95.25	7.92	11.91	0.76	48	71	ANSI 900/1500LB 2B
5	05	114	82.55	7.92	11.91	0.76	48	71	ANSI 2500LB 1½B
6	06	133	101.60	7.92	11.91	0.76	48	71	ANSI 2500LB 2B

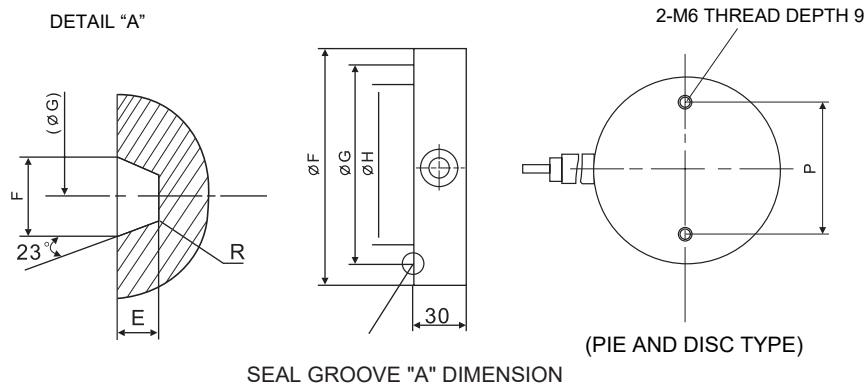

Note: Flange is not in the scope of supply when ording the pie and disc type transmitter.
The mounting flange matched by users, please refer to the other views.

FKX

Table 9 Explosion proof

Authorities	Intrinsic safety	Authorities	Flameproof																				
ATEX	Ex II 1 G Ex ia II C T5 Tamb = -40°C ~ +50°C Ex ia II C T4 Tamb = -40°C ~ +70°C	ATEX	Ex II 2 GD EEx d II C T6 IP66/67 T85°C Tamb = -40°C ~ +65°C EEx d II C T5 IP66/67 T100°C Tamb = -40°C ~ +85°C																				
	Entity Parameters: Ui = 28V, Ii = 94.3mA, Pi = 0.66W Ci = 26nF(without arrester), Li = 0.6mH(without analog indicator) Ci = 36nF(with arrester), Li = 0.7mH(with analog indicator)		FM	Class I Div.1 Groups B, C, D T6 Type 4X Class II III Div.1 Groups E, F, G T6 Type 4X Tamb max = +60°C																			
FM	Class I II III DIV.1 Groups A, B, C, D, E, F, G T4 Entity Type 4X	CSA	Class I Div.1 Groups C, D Class II Div.1 Groups E, F, G Class III Div.1 Note) "Seal Not Required" enclosure is allowed.																				
	<table border="1"> <thead> <tr> <th colspan="2">Model</th> <th>Tamb</th> </tr> <tr> <th>9th digit</th> <th>13th digit</th> <th></th> </tr> </thead> <tbody> <tr> <td>A, B, D</td> <td>Y, G, N</td> <td>-40°C ~ +85°C</td> </tr> <tr> <td>L, P, 1, 2</td> <td>Y, G, N</td> <td>-20°C ~ +80°C</td> </tr> <tr> <td>Q, S, 4, 5</td> <td>Y, G, N</td> <td>-20°C ~ +60°C</td> </tr> <tr> <td>E, F, H</td> <td>Y, G, N</td> <td>-40°C ~ +60°C</td> </tr> <tr> <td>-</td> <td>W, A, D</td> <td>-10°C ~ +60°C</td> </tr> </tbody> </table>		Model		Tamb	9th digit	13th digit		A, B, D	Y, G, N	-40°C ~ +85°C	L, P, 1, 2	Y, G, N	-20°C ~ +80°C	Q, S, 4, 5	Y, G, N	-20°C ~ +60°C	E, F, H	Y, G, N	-40°C ~ +60°C	-	W, A, D	-10°C ~ +60°C
Model		Tamb																					
9th digit	13th digit																						
A, B, D	Y, G, N	-40°C ~ +85°C																					
L, P, 1, 2	Y, G, N	-20°C ~ +80°C																					
Q, S, 4, 5	Y, G, N	-20°C ~ +60°C																					
E, F, H	Y, G, N	-40°C ~ +60°C																					
-	W, A, D	-10°C ~ +60°C																					
CSA	Class I Div.1 Groups A, B, C, D Class II Div.1 Groups E, F, G Class III Div.1	IECEX Scheme	Ex d II C T5 IP66/67 Tamb = -40°C ~ +85°C Ex d II C T6 IP66/67 Tamb = -40°C ~ +65°C																				
	Temp code T5 Tamb max = +50°C Temp code T4 Tamb max = +70°C Entity Parameters: Vmax = 28V Imax = 94.3mA Ci = 25nF(without arrester), Li = 0.6mH(without analog indicator) Ci = 36nF(with arrester), Li = 0.7mH(with abalig indicator)		NEPSI	Ex d II B+H2 T6 Tamb = -40°C ~ +60°C																			
TIIS	Ex ia IIC T4 Tamb max = +60°C Entity Parameters: Ui = 28V, Ii = 94.3mA, Pi = 0.66W, Ci = 38.4nF, Li = 0.694mH	<table border="1"> <thead> <tr> <th>Authorities</th> <th>Type n Nonincendive</th> </tr> </thead> <tbody> <tr> <td rowspan="2">ATEX</td> <td>Ex II 3 GD EEx nL IIC T5 Tamb = -40°C ~ +50°C EEx nL IIC T4 Tamb = -40°C ~ +70°C Specific Parameters: Model without arrester: Ui=42.4V, Ii=113mA, Pi=1W, Ci=25.18nF, Li=0.694mH Model with arrester: Ui=32V, Ii=113mA, Pi=1W, Ci=35.98nF, Li=0.694mH</td> </tr> <tr> <td>EEx nAL IIC T5 Tamb = -40°C ~ +50°C EEx nAL IIC T4 Tamb = -40°C ~ +70°C Specific Parameters: Model without arrester: Umax=42.4V, Imax=113mA, Pmax=1W Model with arrester: Umax=32V, Imax=113mA, Pmax=1W</td> </tr> </tbody> </table>		Authorities	Type n Nonincendive	ATEX	Ex II 3 GD EEx nL IIC T5 Tamb = -40°C ~ +50°C EEx nL IIC T4 Tamb = -40°C ~ +70°C Specific Parameters: Model without arrester: Ui=42.4V, Ii=113mA, Pi=1W, Ci=25.18nF, Li=0.694mH Model with arrester: Ui=32V, Ii=113mA, Pi=1W, Ci=35.98nF, Li=0.694mH	EEx nAL IIC T5 Tamb = -40°C ~ +50°C EEx nAL IIC T4 Tamb = -40°C ~ +70°C Specific Parameters: Model without arrester: Umax=42.4V, Imax=113mA, Pmax=1W Model with arrester: Umax=32V, Imax=113mA, Pmax=1W															
Authorities	Type n Nonincendive																						
ATEX	Ex II 3 GD EEx nL IIC T5 Tamb = -40°C ~ +50°C EEx nL IIC T4 Tamb = -40°C ~ +70°C Specific Parameters: Model without arrester: Ui=42.4V, Ii=113mA, Pi=1W, Ci=25.18nF, Li=0.694mH Model with arrester: Ui=32V, Ii=113mA, Pi=1W, Ci=35.98nF, Li=0.694mH																						
	EEx nAL IIC T5 Tamb = -40°C ~ +50°C EEx nAL IIC T4 Tamb = -40°C ~ +70°C Specific Parameters: Model without arrester: Umax=42.4V, Imax=113mA, Pmax=1W Model with arrester: Umax=32V, Imax=113mA, Pmax=1W																						
IECEX Scheme	Ex ia II C T4 Tamb = -40°C ~ +70°C Ex ia II C T5 Tamb = -40°C ~ +50°C Entity Parameters: Ui = 28V Ii = 94.3mA Pi = 0.66W Ci = 26nF(without arrester), Li = 0.6mH(without analog indicator) Ci = 36nF(with arrester), Li = 0.7mH(with abalig indicator)	FM	Class I II III Div.2 Groups A, B, C, D, F, G T4 Entity Type 4X																				
NEPSI	Ex ia IIC T4 Ex d IIB+H2T6/Ex ia IIC T4		<table border="1"> <thead> <tr> <th colspan="2">Model</th> <th>Tamb</th> </tr> <tr> <th>9th digit</th> <th>13th digit</th> <th></th> </tr> </thead> <tbody> <tr> <td>A, B, D</td> <td>Y, G, N</td> <td>-40°C ~ +85°C</td> </tr> <tr> <td>L, P, 1, 2</td> <td>Y, G, N</td> <td>-20°C ~ +80°C</td> </tr> <tr> <td>Q, S, 4, 5</td> <td>Y, G, N</td> <td>-20°C ~ +60°C</td> </tr> <tr> <td>E F H</td> <td>Y, G, N</td> <td>-40°C ~ +60°C</td> </tr> <tr> <td>-</td> <td>W, A, D</td> <td>-10°C ~ +60°C</td> </tr> </tbody> </table>	Model		Tamb	9th digit	13th digit		A, B, D	Y, G, N	-40°C ~ +85°C	L, P, 1, 2	Y, G, N	-20°C ~ +80°C	Q, S, 4, 5	Y, G, N	-20°C ~ +60°C	E F H	Y, G, N	-40°C ~ +60°C	-	W, A, D
Model		Tamb																					
9th digit	13th digit																						
A, B, D	Y, G, N	-40°C ~ +85°C																					
L, P, 1, 2	Y, G, N	-20°C ~ +80°C																					
Q, S, 4, 5	Y, G, N	-20°C ~ +60°C																					
E F H	Y, G, N	-40°C ~ +60°C																					
-	W, A, D	-10°C ~ +60°C																					
	Entity Parameters: Ui = 42.4V, Ii = 113mA, Pi = 1W, Ci = 35.98nF, Li = 0.694mH	CSA	Class I Div.2 Groups A, B, C, D Class II Div.2 Groups E, F, G Class III Div.2 Temp code T5 Tamb max = +50°C Temp code T4 Tamb max = +70°C Entity Parameters: Vmax=28V, Ci=25.18nF (without arrester), Ci=35.98nF (with arrester), Li=0.694mH																				

Caution on Safety

* Before using this product, be sure to read its instruction manual in advance.

